



ENVIRONMENTAL TECHNOLOGY

CSS™ / CSSN™

CDP™ / CDPN™

Single & Double Cartridge Seal Ranges

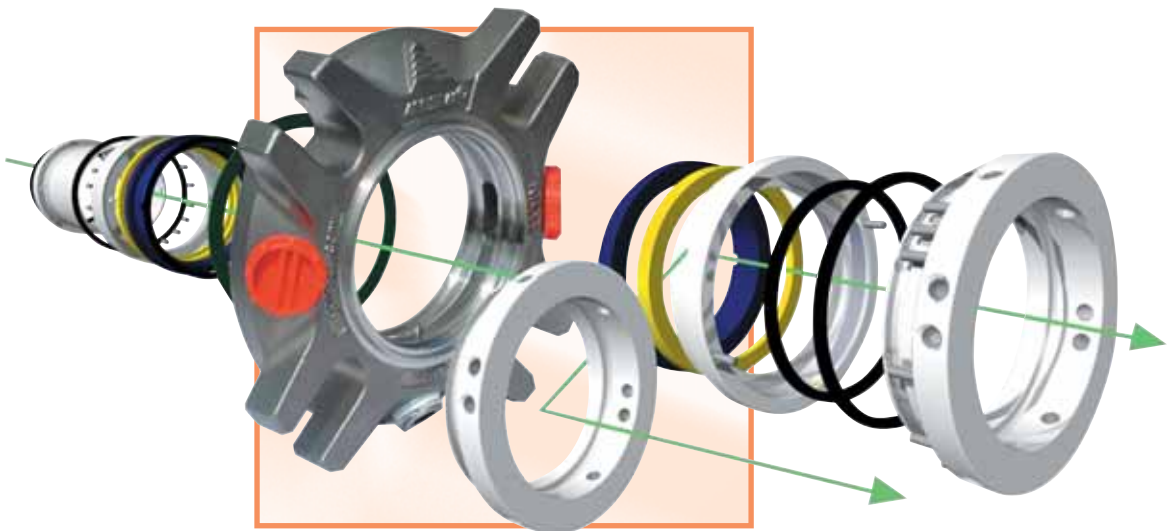

- CARTRIDGE SEALS FOR RELIABLE INSTALLATION
- BALANCED SEAL DESIGN
- NO SHAFT FRETTING
- ROBUST DESIGN
- REGISTERED DESIGNS

AESSEAL® is one of the major specialists in the design and manufacture of mechanical seals and support systems.

**Mechanical seals are used in pumps and rotating equipment to prevent liquids and gases from escaping into the environment.**



AESSEAL plc Group Headquarters, Rotherham, UK.

Growth in excess of 20% per year has allowed AESSEAL® to become the only major international new entrant to the mechanical seals industry in the last twenty years.

The current range of products is also expanding to cover new markets and niches. Continued improvement of existing products and design excellence help AESSEAL® achieve superior product performance.

Industry leading modular design is proven to decrease costs and increase equipment up-time.

**The AESSEAL® CSS™/CSSN™ and CDP™/CDPN™ ranges of cartridge mechanical seals have been designed as high performance sealing solutions for general applications.**

These products build on over a decade of proven performance from the AESSEAL® CURC™ and CDSA™ range of seals. They combine this with cutting edge manufacturing techniques to represent the best value for money sealing solutions available today.

CSSN™



The modular system allows 10 million seal permutations, ensuring AESSEAL® can supply the right solution to meet the customers time frame.

The AESSEAL® modular sealing system combined with unrivalled inventory levels ensure that ANY standard seal in any size or material combination is available for despatch immediately.

CDPN™



AESSEAL® does not believe in “just in time”. Relative to sales, we believe that we hold the highest level of inventory in the industry and as a result we can offer the best delivery performance.



## Two standard gland configurations

For sizes from 1.000" to 3.500" (24-85mm) the seal is a CSSN™ or CDPN™. The CSS™ / CDP™ are available from 3.625" to 4.750" (90-120mm).

1/4" NPT flush / vent port supplied with a stainless steel blanking plug as standard.

Fits both small and ANSI+ box bore pumps without modification.

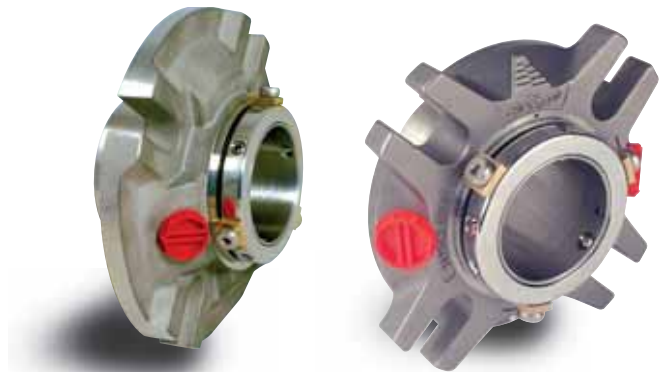

CSS™ Cartridge Single Mechanical Seal

## Modular seal face design

Hydraulically balanced face design ensures optimum fluid film during process fluctuations.

A wide range of inventoried materials allows maximum flexibility and delivery performance.

Metal-to-metal pin drive eliminates potential impact damage.

## Captured rotary 'O' ring

Captured 'O' ring design prevents extrusion under vacuum conditions.

## Multi-spring design

Alloy 276 helical coil springs ensure accurate uniform seal face loading throughout the seal life.

Springs are placed out of the product media to eliminate clogging and loss of face loading.

## Reliable drive

Drive screws clamp directly on to shaft or sleeve to minimise drive loss.

Drive screws which do not deform the seal sleeve ensure easy removal and refitting for equipment maintenance.

Robust setting clips guarantee correct working length and can be re-used for removal and refitting.



CDP™ Cartridge Double Mechanical Seal

# CSS™

3.625" to 4.750" (90mm - 120mm)

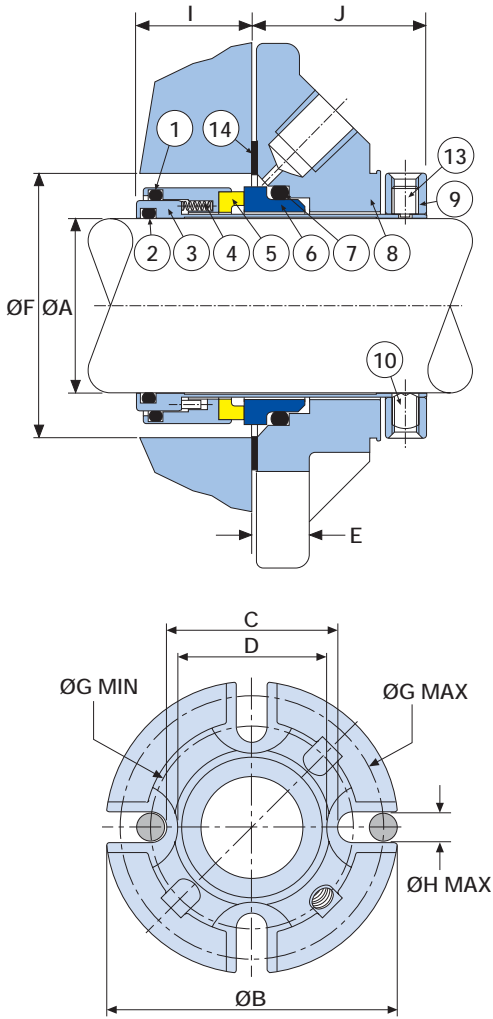

# CSSN™

1.000" to 3.500" (24mm - 85mm)

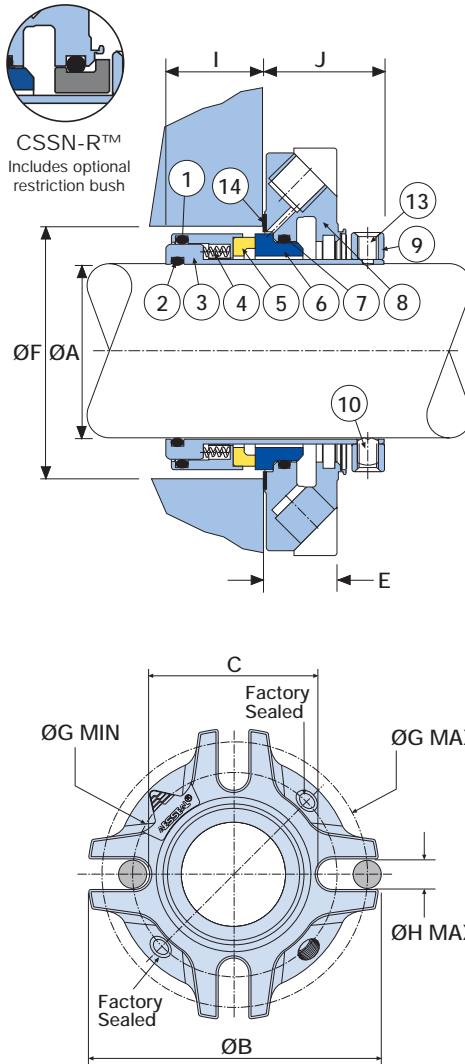

# CSSN™ ANSI+



CSSN-R™ ANSI+  
Includes optional restriction bush

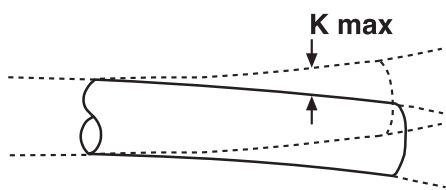
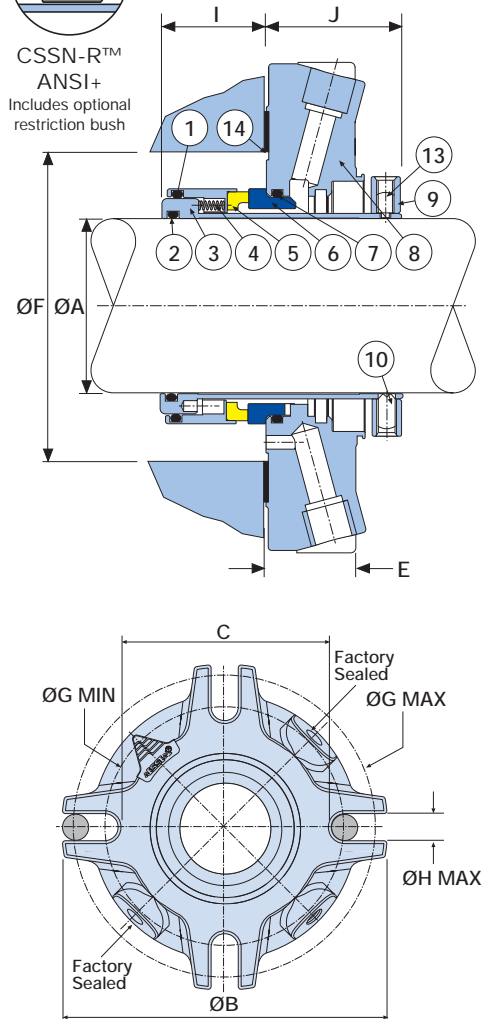

K Max = MAXIMUM TOTAL RADIAL MOVEMENT

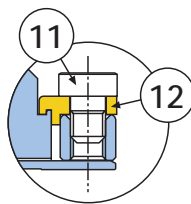

Setting Clip Details

Item	Description	Material
1	Rotary O Ring	Viton® / EPR / Kalrez® / Aflas®
2	Sleeve O Ring	Viton® / EPR / Kalrez® / Aflas®
3	Sleeve	316L Stainless Steel
4	Springs	Alloy 276
5	Rotary Face	316L SS - Carbon / TC / SiC
6	Stationary Face	TC / Ceramic <sup>†</sup> / SiC / 316L SS-Chr.Ox.*
7	Stationary O Ring	Viton® / EPR / Kalrez® / Aflas®
8	Gland	316 Stainless Steel
9	Clamp Ring	316L Stainless Steel
10	Drive Screws	Stainless Steel
11	Clip Screws	Stainless Steel
12	Setting Clips	Hard Plastic / Brass
13	Anti-tamper Screws	Stainless Steel
14	Gasket	AF1 / GFT

All Port Connections are 1/4" NPT.  
\*This material is not available in sizes up to and including 5.500" (140mm).  
†This material is not available from 3.125" (80mm) and above.

# CSS™ / CSSN™ & CSSN™ ANSI+ - size charts

## CSS / CSSN™ - Dimensional Information (inches)

Gland Choice	ØA	ØB	C	D	E	ØF Min	ØF Min†	ØF Max	ØG Min	ØG Max	ØH Max	I	J	KMax
<b>CSSN™</b>														
Sizes from 1.000" - 3.500" are the CSSN™														
1.000	4.125	2.375	-	0.927	1.625	1.665	1.937	2.937	3.625	1/2	1.209	1.467	0.040	
1.125	4.250	2.375	-	0.927	1.750	1.790	2.062	2.937	3.750	1/2	1.209	1.467	0.040	
1.250	4.375	2.500	-	0.927	1.875	1.915	2.187	3.062	3.875	1/2	1.209	1.467	0.040	
1.375	4.375	2.625	-	0.927	2.000	2.040	2.312	3.186	3.875	1/2	1.209	1.467	0.040	
1.500	5.000	2.832	-	0.852	2.250	2.290	2.500	3.375	4.500	1/2	1.090	1.400	0.040	
1.625	5.000	2.832	-	0.852	2.375	2.415	2.500	3.375	4.500	1/2	1.090	1.400	0.040	
1.750	5.250	3.022	-	0.852	2.500	2.540	2.750	3.562	4.750	1/2	1.090	1.400	0.040	
1.875	5.250	3.022	-	0.852	2.625	2.665	2.750	3.562	4.750	1/2	1.090	1.400	0.040	
2.000	5.500	3.386	-	0.852	2.750	2.790	3.000	3.937	5.000	1/2	1.150	1.413	0.040	
2.125	5.750	3.687	-	0.852	2.875	2.915	3.312	4.375	5.125	5/8	1.150	1.413	0.040	
2.250	5.750	3.687	-	0.852	3.000	3.040	3.312	4.375	5.125	5/8	1.150	1.413	0.040	
2.375	6.000	3.937	-	0.852	3.125	3.165	3.562	4.625	5.375	5/8	1.150	1.413	0.040	
2.500	7.000	4.312	-	0.926	3.375	3.435	3.875	5.000	6.375	5/8	1.250	1.500	0.060	
2.625	7.000	4.312	-	0.926	3.500	3.560	3.875	5.000	6.375	5/8	1.250	1.500	0.060	
2.750	7.000	4.312	-	0.926	3.625	3.685	3.875	5.000	6.375	5/8	1.250	1.500	0.060	
2.875	7.500	4.937	-	0.926	3.750	3.810	4.500	5.625	6.812	5/8	1.250	1.500	0.060	
3.000	7.500	4.937	-	0.926	3.875	3.935	4.500	5.625	6.812	5/8	1.250	1.500	0.060	
3.125	7.500	4.937	-	0.926	4.000	4.060	4.500	5.625	6.812	5/8	1.250	1.500	0.060	
3.250	8.000	5.312	-	0.926	4.125	4.185	4.875	6.125	7.312	5/8	1.250	1.500	0.060	
3.375	8.000	5.312	-	0.926	4.250	4.310	4.875	6.125	7.312	5/8	1.250	1.500	0.060	
3.500	8.000	5.312	-	0.926	4.375	4.435	4.875	6.125	7.312	5/8	1.250	1.500	0.060	
<b>CSS™</b>														
Sizes from 3.625" upwards are the CSS™														
3.625	8.500	5.937	5.000	0.769	4.500	4.560	5.000	6.750	7.687	3/4	1.250	1.937	0.060	
3.750	8.500	5.937	5.000	0.769	4.625	4.685	5.125	6.750	7.687	3/4	1.250	1.937	0.060	
3.875	8.500	5.937	5.000	0.769	4.750	4.810	5.250	6.750	7.687	3/4	1.250	1.937	0.060	
4.000	9.000	6.625	5.375	0.769	4.875	4.935	5.500	7.437	8.187	3/4	1.250	1.937	0.060	
4.125	9.000	6.625	5.375	0.769	5.125	5.185	5.875	7.437	8.187	3/4	1.250	1.937	0.060	
4.250	9.000	6.625	5.375	0.769	5.125	5.185	5.875	7.437	8.187	3/4	1.250	1.937	0.060	
4.375	9.500	7.000	5.750	0.769	5.375	5.435	6.250	7.812	8.687	3/4	1.250	1.937	0.060	
4.500	9.500	7.000	5.750	0.769	5.375	5.435	6.250	7.812	8.687	3/4	1.250	1.937	0.060	
4.625	10.000	7.345	6.125	0.769	5.625	5.685	6.625	8.312	9.062	7/8	1.250	1.937	0.060	
4.750	10.000	7.345	6.125	0.769	5.625	5.685	6.625	8.312	9.062	7/8	1.250	1.937	0.060	

† = F Min + K Max

## CSS / CSSN™ - Dimensional Information (mm)

Gland Choice	ØA	ØB	C	D	E	ØF Min	ØF Min†	ØF Max	ØG Min	ØG Max	ØH Max	I	J	K Max
<b>CSSN™</b>														
Sizes from 24mm - 85mm are the CSSN™														
24	104.8	60.3	-	23.5	40.0	41.0	46.0	74.6	92.0	12	30.7	37.3	1.0	
25	104.8	60.3	-	23.5	41.0	42.0	49.2	74.6	92.0	12	30.7	37.3	1.0	
28	108.0	60.3	-	23.5	44.0	45.0	52.4	74.6	95.3	12	30.7	37.3	1.0	
30	111.0	63.5	-	23.5	46.0	47.0	55.6	77.8	98.4	12	30.7	37.3	1.0	
32	111.0	63.5	-	23.5	48.0	49.0	55.6	77.8	98.4	12	30.7	37.3	1.0	
33	111.0	63.5	-	23.5	49.0	50.0	55.6	77.8	98.4	12	30.7	37.3	1.0	
35	111.0	66.7	-	23.5	50.8	51.8	58.7	80.9	98.4	12	30.7	37.3	1.0	
38	127.0	71.9	-	21.6	57.2	58.2	63.5	85.7	114.3	12	27.7	35.6	1.0	
40	127.0	71.9	-	21.6	57.2	58.2	63.5	85.7	114.3	12	27.7	35.6	1.0	
43	127.0	71.9	-	21.6	60.3	61.3	63.5	85.7	114.3	12	27.7	35.6	1.0	
45	133.4	76.7	-	21.6	63.5	64.5	69.8	90.5	120.7	12	27.7	35.6	1.0	
48	133.4	76.7	-	21.6	66.7	67.7	69.8	90.5	120.7	12	27.7	35.6	1.0	
50	133.4	76.7	-	21.6	68.0	69.0	69.8	90.5	120.7	12	27.7	35.6	1.0	
53	139.7	86.0	-	21.6	71.0	72.0	76.2	100.0	127.0	12	29.2	35.9	1.0	
55	146.0	93.7	-	21.6	73.0	74.0	84.1	111.1	130.2	16	29.2	35.9	1.0	
58	146.0	93.7	-	21.6	76.2	77.2	84.1	111.1	130.2	16	29.2	35.9	1.0	
60	152.4	100.0	-	21.6	79.4	80.4	90.5	117.5	136.5	16	29.2	35.9	1.0	
63	177.8	109.5	-	23.5	85.7	87.2	98.4	127.0	161.9	16	31.8	38.1	1.5	
65	177.8	109.5	-	23.5	88.9	90.4	98.4	127.0	161.9	16	31.8	38.1	1.5	
70	177.8	109.5	-	23.5	92.1	93.6	98.4	127.0	161.9	16	31.8	38.1	1.5	
75	190.5	125.4	-	23.5	98.5	100.0	114.3	142.9	173.0	16	31.8	38.1	1.5	
80	190.5	125.4	-	23.5	101.6	103.1	114.3	142.9	173.0	16	31.8	38.1	1.5	
85	203.2	135.0	-	23.5	108.0	109.5	123.7	152.4	185.7	16	31.8	38.1	1.5	
<b>CSS™</b>														
Sizes from 90mm upwards are the CSS™														
90	215.9	150.8	127.0	19.6	114.3	115.8	127.0	171.5	195.2	20	31.8	49.2	1.5	
95	215.9	150.8	127.0	19.6	117.5	119.0	130.2	171.5	195.2	20	31.8	49.2	1.5	
100	228.6	168.3	136.5	19.6	123.9	125.4	139.7	188.9	207.9	20	31.8	49.2	1.5	
105	228.6	168.3	136.5	19.6	130.1	131.6	149.2	189.0	208.0	20	31.8	49.2	1.5	
110	241.3	177.8	146.1	19.6	136.5	138.0	158.8	198.4	220.6	20	31.8	49.2	1.5	
115	254.0	186.6	155.6	19.6	142.9	144.4	168.3	211.1	230.2	22	31.8	49.2	1.5	
120	254.0	186.6	155.6	19.6	142.9	144.4	168.3	211.1	230.2	22	31.8	49.2	1.5	

† = F Min + K Max

## CSSN™ ANSI+ - Dimensional Information (inches)

Gland Choice	ØA	ØB	C	E	ØF Min	ØF Max	ØG Min	ØG Max	ØH Max	I	J	K Max
1.125	4.975	3.174	0.906	2.625	2.850	3.750	4.437	0.500	1.229	1.450	0.040	
1.375	5.328	3.413	0.898	2.875	3.100	4.000	4.812	0.500	1.250	1.438	0.040	
1.750	6.750	4.413	1.058	3.500	4.100	5.000	6.250	0.500	1.196	1.601	0.040	
1.875	6.750	4.413	1.058	3.625	4.100	5.000	6.250	0.500	1.196	1.601	0.040	
2.125	7.600	4.663	0.892	3.875	4.225	5.375	6.875	0.625	1.396	1.459	0.040	
2.500	8.250	5.413	1.137	4.500	5.100	6.125	7.562	0.625	1.451	1.675	0.060	
2.625	8.250	5.413	1.137	4.625	5.100	6.125	7.562	0.625	1.451	1.675	0.060	
2.750	8.250	5.413	1.137	4.625	5.100	6.125	7.562	0.625	1.451	1.675	0.060	

# CDP™

3.625" to 4.750" (90mm - 120mm)

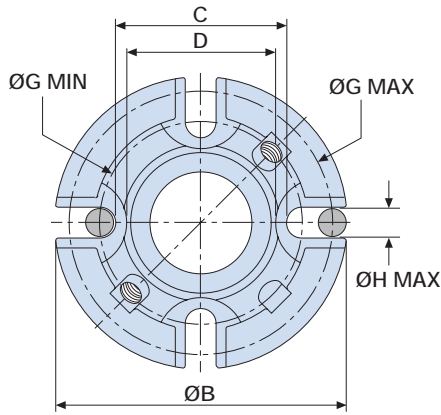
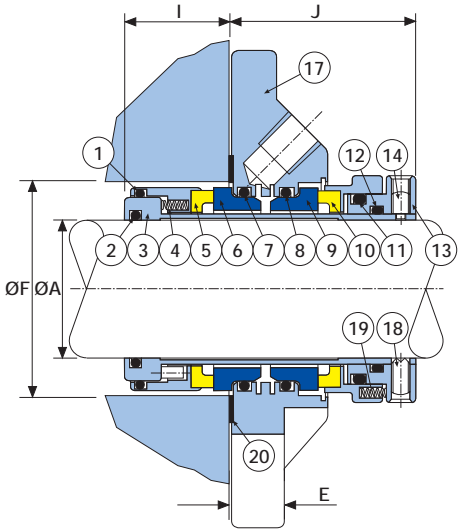

# CDPN™

1.000" to 3.500" (24mm - 85mm)

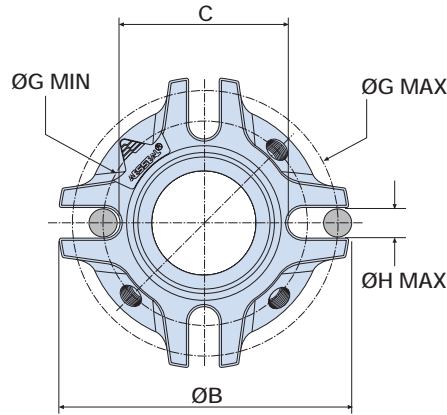
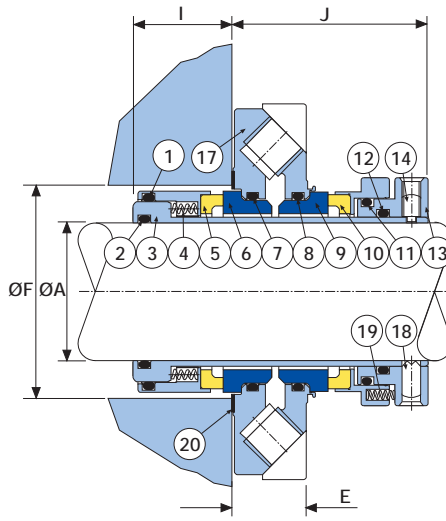

# CDPN™ ANSI+

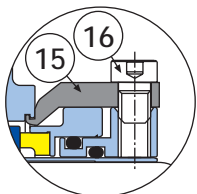
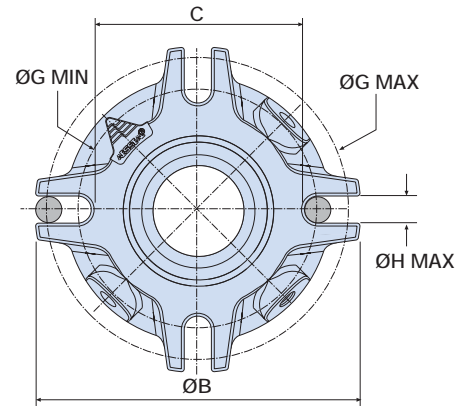
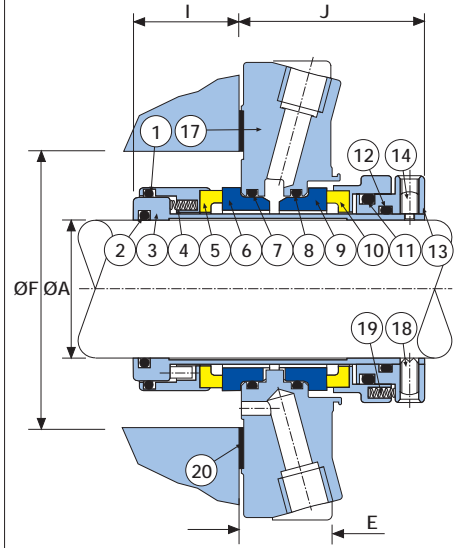

Setting Clip Details

Item	Description	Material	Item	Description	Material
1	Rotary O Ring	Viton® / EPR / Kalrez® / Aflas®	10	Outer Rotary Face	316L SS - Carbon / TC / SiC
2	Sleeve O Ring	Viton® / EPR / Kalrez® / Aflas®	11	Drive Band O Ring	Viton® / EPR / Kalrez® / Aflas®
3	Sleeve	316L Stainless Steel	12	Clamp Ring O Ring	Viton® / EPR / Kalrez® / Aflas®
4	Springs	Alloy 276	13	Clamp Ring	316L Stainless Steel
5	Inner Rotary Face	316L SS - Carbon / TC / SiC	14	Anti-Tamper Screw	316 Stainless Steel
6	Inner Stationary Face	SiC / Ceramic <sup>1</sup> / TC / 316L Stainless Steel-Chr.Ox.*	15	Centering Clips	Brass
7	Stationary O Ring	Viton® / EPR / Kalrez® / Aflas®	16	Clip Screws	316 Stainless Steel
8	Stationary O Ring	Viton® / EPR / Kalrez® / Aflas®	17	Gland	316 Stainless Steel
9	Outer Stationary Face	SiC / Ceramic <sup>1</sup> / TC / 316L Stainless Steel-Chr.Ox.*	18	Drive Screws	316 Stainless Steel
			19	Springs	Alloy 276
			20	Gasket	AF1 / GFT

All Port Connections are 1/4" NPT.  
\*This material is not available in sizes up to and including 5.500" (140mm).

<sup>1</sup>This material is not available from 3.125" (80mm) and above.

Please refer to the back page of this brochure for information on support systems for double seals.

# CDP™ / CDPN™ & CDPN™ ANSI+ - size charts

## CDP / CDPN™ - Dimensional Information (inches)

Gland Choice	ØA	ØB	C	D	E	ØF Min	ØF Min†	ØF Max	ØG Min	ØG Max	ØH Max	I	J	KMax*
CDPN™														
Sizes from 1.000" - 3.500" are the CDPN™														
	1.000	4.125	2.375	-	0.927	1.625	1.665	1.937	2.937	3.625	1/2	1.209	2.020	0.040
	1.125	4.250	2.375	-	0.927	1.750	1.790	2.062	2.937	3.750	1/2	1.209	2.020	0.040
	1.250	4.375	2.500	-	0.927	1.875	1.915	2.187	3.062	3.875	1/2	1.209	2.020	0.040
	1.375	4.375	2.625	-	0.927	2.000	2.040	2.312	3.186	3.875	1/2	1.209	2.020	0.040
	1.500	5.000	2.832	-	0.852	2.250	2.290	2.500	3.375	4.500	1/2	1.090	2.226	0.040
	1.625	5.000	2.832	-	0.852	2.375	2.415	2.500	3.375	4.500	1/2	1.090	2.226	0.040
	1.750	5.250	3.022	-	0.852	2.500	2.540	2.750	3.562	4.750	1/2	1.090	2.226	0.040
	1.875	5.250	3.022	-	0.852	2.625	2.665	2.750	3.562	4.750	1/2	1.090	2.226	0.040
	2.000	5.500	3.386	-	0.852	2.750	2.790	3.000	3.937	5.000	1/2	1.150	2.250	0.040
	2.125	5.750	3.687	-	0.852	2.875	2.915	3.312	4.375	5.125	5/8	1.150	2.250	0.040
	2.250	5.750	3.687	-	0.852	3.000	3.040	3.312	4.375	5.125	5/8	1.150	2.250	0.040
	2.375	6.000	3.937	-	0.852	3.125	3.165	3.562	4.625	5.375	5/8	1.150	2.250	0.040
	2.500	7.000	4.312	-	0.926	3.375	3.435	3.875	5.000	6.375	5/8	1.250	2.510	0.060
	2.625	7.000	4.312	-	0.926	3.500	3.560	3.875	5.000	6.375	5/8	1.250	2.510	0.060
	2.750	7.000	4.312	-	0.926	3.625	3.685	3.875	5.000	6.375	5/8	1.250	2.510	0.060
	2.875	7.500	4.937	-	0.926	3.750	3.810	4.500	5.625	6.812	5/8	1.250	2.510	0.060
	3.000	7.500	4.937	-	0.926	3.875	3.935	4.500	5.625	6.812	5/8	1.250	2.510	0.060
	3.125	7.500	4.937	-	0.926	4.000	4.060	4.500	5.625	6.812	5/8	1.250	2.510	0.060
	3.250	8.000	5.312	-	0.926	4.125	4.185	4.875	6.000	7.312	5/8	1.250	2.510	0.060
	3.375	8.000	5.312	-	0.926	4.250	4.310	4.875	6.000	7.312	5/8	1.250	2.510	0.060
	3.500	8.000	5.312	-	0.926	4.375	4.435	4.875	6.000	7.312	5/8	1.250	2.510	0.060
CDP™														
Sizes from 3.625 upwards are the CDP™														
	3.625	8.500	5.937	5.000	0.769	4.500	4.560	5.000	6.750	7.687	3/4	1.250	2.375	0.060
	3.750	8.500	5.937	5.000	0.769	4.625	4.685	5.125	6.750	7.687	3/4	1.250	2.375	0.060
	3.875	8.500	5.937	5.000	0.769	4.750	4.810	5.250	6.750	7.687	3/4	1.250	2.375	0.060
	4.000	9.000	6.625	5.375	0.769	4.875	4.935	5.500	7.437	8.187	3/4	1.250	2.375	0.060
	4.625	10.000	7.345	6.125	0.769	5.625	5.685	6.625	8.312	9.062	7/8	1.250	2.375	0.060
	4.750	10.000	7.345	6.125	0.769	5.625	5.685	6.625	8.312	9.062	7/8	1.250	2.375	0.060

† = F Min + K Max

\*For K Max explanation please refer to page 4.

## CDP / CDPN™ - Dimensional Information (mm)

Gland Choice	ØA	ØB	C	D	E	ØF Min	ØF Min†	ØF Max	ØG Min	ØG Max	ØH Max	I	J	KMax*
CDPN™														
Sizes from 24mm - 85mm are the CDPN™														
	24	104.8	60.3	-	23.5	40.0	41.0	46.0	74.6	92.0	12	30.7	51.3	1.0
	25	104.8	60.3	-	23.5	41.0	42.0	49.2	74.6	92.0	12	30.7	51.3	1.0
	28	108.0	60.3	-	23.5	44.0	45.0	52.4	74.6	95.3	12	30.7	51.3	1.0
	30	111.0	63.5	-	23.5	46.0	47.0	55.6	77.8	98.4	12	30.7	51.3	1.0
	32	111.0	63.5	-	23.5	48.0	49.0	55.6	77.8	98.4	12	30.7	51.3	1.0
	33	111.0	63.5	-	23.5	49.0	50.0	55.6	77.8	98.4	12	30.7	51.3	1.0
	35	111.0	66.7	-	23.5	50.8	51.8	58.7	80.9	98.4	12	30.7	51.3	1.0
	38	127.0	71.9	-	21.6	57.2	58.2	63.5	85.7	114.3	12	27.7	56.5	1.0
	40	127.0	71.9	-	21.6	57.2	58.2	63.5	85.7	114.3	12	27.7	56.5	1.0
	43	127.0	71.9	-	21.6	60.3	61.3	63.5	85.7	114.3	12	27.7	56.5	1.0
	45	133.4	76.7	-	21.6	63.5	64.5	69.8	90.5	120.7	12	27.7	56.5	1.0
	48	133.4	76.7	-	21.6	66.7	67.7	69.8	90.5	120.7	12	27.7	56.5	1.0
	50	133.4	76.7	-	21.6	68.0	69.0	69.8	90.5	120.7	12	27.7	56.5	1.0
	53	139.7	86.0	-	21.6	71.0	72.0	76.2	100.0	127.0	12	29.2	57.2	1.0
	55	146.0	93.7	-	21.6	73.0	74.0	84.1	111.1	130.2	16	29.2	57.2	1.0
	58	146.0	93.7	-	21.6	76.2	77.2	84.1	111.1	130.2	16	29.2	57.2	1.0
	60	152.4	100.0	-	21.6	79.4	80.4	90.5	117.5	136.5	16	29.2	57.2	1.0
	63	177.8	109.5	-	23.5	85.7	87.2	98.4	127.0	161.9	16	31.8	63.8	1.5
	65	177.8	109.5	-	23.5	88.9	90.4	98.4	127.0	161.9	16	31.8	63.8	1.5
	70	177.8	109.5	-	23.5	92.1	93.6	98.4	127.0	161.9	16	31.8	63.8	1.5
	75	190.5	125.4	-	23.5	98.5	100.0	114.3	142.9	173.0	16	31.8	63.8	1.5
	80	190.5	125.4	-	23.5	101.6	103.1	114.3	142.9	173.0	16	31.8	63.8	1.5
	85	203.2	135.0	-	23.5	108.0	109.5	123.7	152.4	185.7	16	31.8	63.8	1.5
CDP™														
Sizes from 90mm upwards are the CDP™														
	90	215.9	150.8	127.0	19.6	114.3	115.8	127.0	171.5	195.2	20	31.8	60.3	1.5
	95	215.9	150.8	127.0	19.6	117.5	119.0	130.2	171.5	195.2	20	31.8	60.3	1.5
	100	228.6	168.3	136.5	19.6	123.9	125.4	139.7	188.9	207.9	20	31.8	60.3	1.5
	115	254.0	186.6	155.6	19.6	142.9	144.4	168.3	211.1	230.2	22	31.8	60.3	1.5
	120	254.0	186.6	155.6	19.6	142.9	144.4	168.3	211.1	230.2	22	31.8	60.3	1.5

† = F Min + K Max

\*For K Max explanation please refer to page 4.

## CDPN™ ANSI+ - Dimensional Information (inches)

Gland Choice	ØA	ØB	C	E	ØF Min	ØF Max	ØG Min	ØG Max	ØH Max	I	J	K Max*
	1.125	4.975	3.174	0.906	2.625	2.850	3.750	4.437	0.500	1.229	2.000	0.040
	1.375	5.328	3.413	0.898	2.875	3.100	4.000	4.812	0.500	1.250	2.000	0.040
	1.750	6.750	4.413	1.058	3.500	4.100	5.000	6.250	0.500	1.196	2.119	0.040
	1.875	6.750	4.413	1.058	3.625	4.100	5.000	6.250	0.500	1.196	2.119	0.040
	2.125	7.600	4.663	0.892	3.875	4.225	5.375	6.875	0.625	1.396	2.000	0.040
	2.500	8.250	5.413	1.137	4.500	5.100	6.125	7.562	0.625	1.451	2.187	0.060
	2.625	8.250	5.413	1.137	4.625	5.100	6.125	7.562	0.625	1.451	2.187	0.060
	2.750	8.250	5.413	1.137	4.625	5.100	6.125	7.562	0.625	1.451	2.187	0.060

\*For K Max explanation please refer to page 4.

# SMSS™ & DMSF™ - single and double monolithic designs

The CSSN™ and CDPN™ range of cartridge mechanical seals is complemented by the high performance SMSS™ and DMSF™ monolithic designs.

Available from 1.000" to 6.000" (24mm to 150mm), the patented DMSF™ stationary design includes double balanced seal faces designed to withstand barrier and process pressure fluctuations.

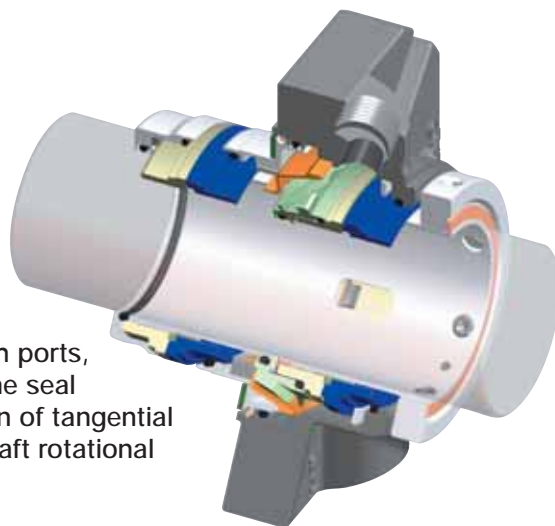

The SMSS™ has two flush ports, positioned directly over the seal faces, providing the option of tangential flushing irrespective of shaft rotational direction.

The DMSF™ is supplied with a highly efficient integral bi-directional pumping ring and deflector arrangement, which circulates and directs barrier fluid to the critical places within the seal.

Both SMSS™ and DMSF™ products employ modular components, thereby increasing availability and reducing product lead time.

## Environmental Control Systems for double seals

In addition to a vast range of mechanical seals, AESSEAL® has a specialized systems division, dedicated to the design and manufacture of a comprehensive range of seal support packages for double mechanical seals. The AESSEAL® Support Systems offering ranges from the FLOWTRUE™ flow meter device, to the SWFF-TF™ thermosyphon system, the high pressure AES-15 system and the PUMPPAC™ forced circulation system.

SWFF-TF™



FLOWTRUE™



AES-15™



PUMPPAC™



The systems above are compatible with a wide selection of barrier and buffer fluid media. They are supplied pre-assembled with all necessary components and fittings. On site inventory costs are reduced by modular system construction.

THIS DOCUMENT IS DESIGNED TO PROVIDE DIMENSIONAL INFORMATION AND AN INDICATION OF AVAILABILITY. FOR FURTHER INFORMATION AND SAFE OPERATING LIMITS CONTACT OUR TECHNICAL SPECIALISTS AT THE LOCATIONS BELOW.



INVESTOR IN PEOPLE



THE QUEEN'S AWARDS  
FOR ENTERPRISE  
INNOVATION  
2006

USE DOUBLE MECHANICAL SEALS WITH HAZARDOUS PRODUCTS. ALWAYS TAKE SAFETY PRECAUTIONS:

- GUARD YOUR EQUIPMENT
- WEAR PROTECTIVE CLOTHING



WARNING

**UK Sales & Technical advice:**

AESSEAL plc  
Mill Close  
Templeborough  
Rotherham  
S60 1BZ  
United Kingdom

Telephone: +44 (0) 1709 369966  
Fax: +44 (0) 1709 720788  
E-mail: seals@aes seal.com  
Internet: http://www.aes seal.com

Distributed by:

**Our Purpose:** *'To give our customers such exceptional service that they need never consider alternative sources of supply.'*

**USA Sales & Technical advice:**

AESSEAL Inc.  
355 Dunavant Drive  
Rockford  
TN. 37853  
USA

Telephone: +1 865 531 0192  
Fax: +1 865 531 0571  
E-mail: usa@aes seal.com

**Systems Sales & Technical advice:**

AESSEAL (MCK) Ltd.  
139A Hillsborough Old Road  
Lisburn  
N.Ireland  
BT27 5QE

Telephone: +44 (0) 28 9266 9966  
Fax: +44 (0) 28 9266 9977  
Tel/Fax Hotline: +44 (0) 28 9266 9988  
E-mail: MCK@aes seal.co.uk

ALL SIZES ARE SUBJECT TO MANUFACTURING TOLERANCES. WE RESERVE THE RIGHT TO MODIFY SPECIFICATIONS AT ANY TIME.